

## Product Overview

The NSi812x devices are high reliability dual-channel digital isolator. The NSi812x device is safety certified by UL1577 support several insulation withstand voltages (3.75kV<sub>rms</sub>, 5kV<sub>rms</sub>), while providing high electromagnetic immunity and low emissions at low power consumption. The data rate of the NSi812x is up to 150Mbps, and the common-mode transient immunity (CMTI) is up to 150kV/us. The NSi812x device provides digital channel direction configuration and the default output level configuration when the input power is lost. Wide supply voltage of the NSi812x device support to connect with most digital interface directly, easy to do the level shift. High system level EMC performance enhance reliability and stability of use. AEC-Q100 (Grade 1) option is provided for all devices.

## Key Features

- Up to 5000V<sub>rms</sub> Insulation voltage
- Data rate: DC to 150Mbps
- Power supply voltage: 2.5V to 5.5V
- All devices are AEC-Q100 qualified
- High CMTI: 150kV/us
- Chip level ESD: HBM: ±6kV
- High system level EMC performance:
  - Enhanced system level ESD, EFT, Surge immunity
- Default output high level or low level option
- Isolation barrier life: >60 years
- Low power consumption: 1.5mA/ch (1 Mbps)
- Low propagation delay: <15ns
- Operation temperature: -40°C~125°C
- RoHS-compliant packages:
  - SOIC-8 narrow body
  - SOIC-16 wide body

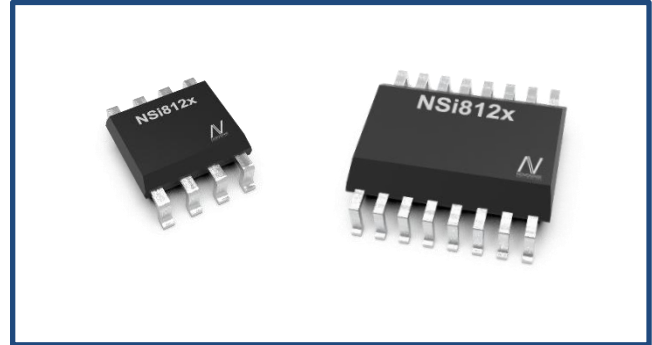

## Safety Regulatory Approvals

- UL recognition: up to 5000V<sub>rms</sub> for 1 minute per UL1577
- CQC certification per GB4943.1-2011
- CSA component notice 5A
- DIN VDE V 0884-11:2017-01

## Applications

- Industrial automation system
- Isolated SPI, RS232, RS485
- General-purpose multichannel isolation
- Motor control

## Functional Block Diagrams

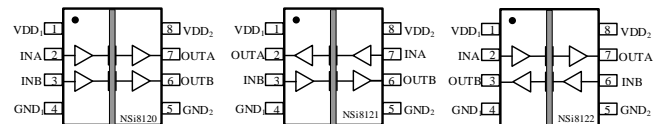

Figure 1. NSi812xN Block Diagram

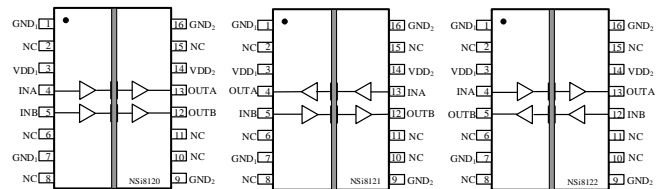

Figure 2. NSi812xW Block Diagram

## Index

<b>1.0</b>	<b>ABSOLUTE MAXIMUM RATINGS</b> .....	<b>3</b>
<b>2.0</b>	<b>SPECIFICATIONS</b> .....	<b>3</b>
2.1.	RECOMMENDED OPERATING CONDITIONS .....	3
2.2.	THERMAL CHARACTERISTICS .....	3
2.3.	ELECTRICAL CHARACTERISTICS .....	4
2.4.	TYPICAL PERFORMANCE CHARACTERISTICS .....	8
2.5.	PARAMETER MEASUREMENT INFORMATION .....	8
<b>3.0</b>	<b>HIGH VOLTAGE FEATURE DESCRIPTION</b> .....	<b>9</b>
3.1.	INSULATION AND SAFETY RELATED SPECIFICATIONS .....	9
3.2.	DIN VDE V 0884-11 ( VDE V 0884-11 ) :2017-01 INSULATION CHARACTERISTICS .....	9
3.3.	REGULATORY INFORMATION.....	11
<b>4.0</b>	<b>FUNCTION DESCRIPTION</b> .....	<b>12</b>
<b>5.0</b>	<b>APPLICATION NOTE</b> .....	<b>12</b>
5.1.	PCB LAYOUT.....	12
5.2.	HIGH SPEED PERFORMANCE.....	13
5.3.	TYPICAL SUPPLY CURRENT EQUATIONS.....	13
<b>6.0</b>	<b>PACKAGE INFORMATION</b> .....	<b>14</b>
<b>7.0</b>	<b>TAPE AND REEL INFORMATION</b> .....	<b>17</b>
<b>8.0</b>	<b>ORDER INFORMATION</b> .....	<b>20</b>
<b>9.0</b>	<b>REVISION HISTORY</b> .....	<b>21</b>

## 1.0 ABSOLUTE MAXIMUM RATINGS

Parameters	Symbol	Min	Typ	Max	Unit	Comments
Power Supply Voltage	VDD1, VDD2	-0.5		6.5	V	
Maximum Input Voltage	VINA, VINB	-0.4		VDD+0.4 <sup>1</sup>	V	
Maximum Output Voltage	V <sub>OUTA</sub> , V <sub>OUTB</sub>	-0.4		VDD+0.4 <sup>1</sup>	V	
Maximum Input/Output Pulse Voltage	VINA, VINB, V <sub>OUTA</sub> , V <sub>OUTB</sub>	-0.8		VDD+0.8	V	Pulse width should be less than 100ns, and the duty cycle should be less than 10%
Common-Mode Transients	CMTI			±150	kV/us	
Output current	I <sub>o</sub>	-15		15	mA	
Maximum Surge Isolation Voltage	V <sub>IOSM</sub>			5.3	kV	
Operating Temperature	T <sub>opr</sub>	-40		125	°C	
Junction temperature	T <sub>j</sub>	-40		150	°C	
Storage Temperature	T <sub>stg</sub>	-40		150	°C	
Electrostatic discharge	HBM			±6000	V	
	CDM			±2000	V	

<sup>1</sup>The maximum voltage must not exceed 6.5V.

## 2.0 SPECIFICATIONS

### 2.1. RECOMMENDED OPERATING CONDITIONS

Parameters	Symbol	min	typ	max	unit
Power Supply Voltage	VDD1, VDD2	2.5		5.5	V
Operating Temperature	T <sub>opr</sub>	-40		125	°C
High Level Input Voltage	V <sub>IH</sub>	2			V
Low Level Input Voltage	V <sub>IL</sub>			0.8	V
Data rate	DR			150	Mbps

### 2.2. THERMAL CHARACTERISTICS

Parameters	Symbol	WB SOIC-16	NB-SOIC-8	Unit
IC Junction-to-Air Thermal Resistance	$\theta_{JA}$	86.5	137.7	° C/W
Junction-to-case (top) thermal resistance	$\theta_{JC (top)}$	49.6	54.9	° C/W

# NSi8120/NSi8121/NSi8122

Junction-to-board thermal resistance	$\theta_{JB}$	49.7	71.7	° C/W
--------------------------------------	---------------	------	------	-------

## 2.3. ELECTRICAL CHARACTERISTICS

(VDD1=2.5V~5.5V, VDD2=2.5V~5.5V, Ta=-40°C to 125°C. Unless otherwise noted, Typical values are at VDD1 = 5V, VDD2 = 5V, Ta = 25°C)

Parameters	Symbol	Min	Typ	Max	Unit	Comments
Power on Reset	VDD <sub>POR</sub>		2.2		V	POR threshold as during power-up
	VDD <sub>HYS</sub>		0.1		V	POR threshold Hysteresis
Input Threshold	V <sub>IT</sub>		1.6		V	Input Threshold at rising edge
	V <sub>IT_HYS</sub>		0.4		V	Input Threshold Hysteresis
High Level Input Voltage	V <sub>IH</sub>	2			V	
Low Level Input Voltage	V <sub>IL</sub>			0.8	V	
High Level Output Voltage	V <sub>OH</sub>	VDD-0.3			V	I <sub>OH</sub> ≤ 4mA
Low Level Output Voltage	V <sub>OL</sub>			0.3	V	I <sub>OL</sub> ≤ 4mA
Output Impedance	R <sub>out</sub>		50		ohm	
Input Pull high or low Current	I <sub>pull</sub>		8	15	uA	
Start Up Time after POR	tr <sub>bs</sub>		40		usec	
Common Mode Transient Immunity	CMTI	±100		±150	kV/us	

(VDD1=5V± 10%, VDD2=5V± 10%, Ta=-40°C to 125°C. Unless otherwise noted, Typical values are at VDD1 = 5V, VDD2 = 5V, Ta = 25°C)

Parameters	Symbol	Min	Typ	Max	Unit	Comments
Supply current	<b>NSi8120</b>					
	I <sub>DD1</sub> (Q0)		0.58	0.87	mA	All Input 0V for NSi8120x0 Or All Input at supply for NSi8120x1
	I <sub>DD2</sub> (Q0)		1.18	1.77	mA	
	I <sub>DD1</sub> (Q1)		2.92	4.38	mA	All Input at supply for NSi8120x0 Or All Input 0V for NSi8120x1
	I <sub>DD2</sub> (Q1)		1.24	1.86	mA	
	I <sub>DD1</sub> (1M)		1.71	2.56	mA	All Input with 1Mbps, C <sub>L</sub> =15pF
	I <sub>DD2</sub> (1M)		1.38	2.07	mA	
	I <sub>DD1</sub> (10M)		1.78	2.67	mA	All Input with 10Mbps, C <sub>L</sub> =15pF
	I <sub>DD2</sub> (10M)		3.2	4.8	mA	
I <sub>DD1</sub> (100M)		2.10	3.15	mA	All Input with 100Mbps,	

# NSi8120/NSi8121/NSi8122

	I <sub>DD2</sub> (100M)		21.0	31.5	mA	C <sub>L</sub> =15pF
<b>NSi8121/ NSi8122</b>						
	I <sub>DD1</sub> (Q0)		1.03	1.55	mA	All Input 0V for NSi812xx0 Or All Input at supply for NSi812xx1
	I <sub>DD2</sub> (Q0)		1.00	1.5	mA	
	I <sub>DD1</sub> (Q1)		2.20	3.3	mA	All Input at supply for NSi812xx0 Or All Input 0V for NSi812xx1
	I <sub>DD2</sub> (Q1)		2.13	3.2	mA	
	I <sub>DD1</sub> (1M)		1.72	2.58	mA	All Input with 1Mbps, C <sub>L</sub> =15pF
	I <sub>DD2</sub> (1M)		1.68	2.52	mA	
	I <sub>DD1</sub> (10M)		2.62	3.93	mA	All Input with 10Mbps, C <sub>L</sub> =15pF
	I <sub>DD2</sub> (10M)		2.71	4.06	mA	
	I <sub>DD1</sub> (100M)		11.01	16.5	mA	All Input with 100Mbps, C <sub>L</sub> = 15pF
	I <sub>DD2</sub> (100M)		12.8	19.2	mA	
Data Rate	DR	0		150	Mbps	
Minimum Pulse Width	PW			5.0	ns	
Propagation Delay	t <sub>PLH</sub>	5	8.20	15	ns	See <a href="#">Figure 2.7</a> , C <sub>L</sub> = 15pF
	t <sub>PHL</sub>	5	10.56	15	ns	See <a href="#">Figure 2.7</a> , C <sub>L</sub> = 15pF
Pulse Width Distortion  t <sub>PHL</sub> - t <sub>PLH</sub>	PWD			5.0	ns	See <a href="#">Figure 2.7</a> , C <sub>L</sub> = 15pF
Rising Time	t <sub>r</sub>			5.0	ns	See <a href="#">Figure 2.7</a> , C <sub>L</sub> = 15pF
Falling Time	t <sub>f</sub>			5.0	ns	See <a href="#">Figure 2.7</a> , C <sub>L</sub> = 15pF
Peak Eye Diagram Jitter	t <sub>JIT</sub> (PK)		350		ps	
Channel-to-Channel Delay Skew	t <sub>SK</sub> (c2c)			2.5	ns	
Part-to-Part Delay Skew	t <sub>SK</sub> (p2p)			5.0	ns	

(VDD1=3.3V± 10%, VDD2=3.3V± 10%, Ta=-40°C to 125°C. Unless otherwise noted, Typical values are at VDD1 = 3.3V, VDD2 = 3.3V, Ta = 25°C)

Parameters	Symbol	Min	Typ	Max	Unit	Comments
Supply current	<b>NSi8120</b>					
	I <sub>DD1</sub> (Q0)		0.55	0.83	mA	All Input 0V for NSi8120x0 Or All Input at supply for NSi8120x1
	I <sub>DD2</sub> (Q0)		1.12	1.68	mA	
	I <sub>DD1</sub> (Q1)		2.87	4.3	mA	All Input at supply for NSi8120x0 Or All Input 0V for NSi8120x1
I <sub>DD2</sub> (Q1)		1.18	1.77	mA		

# NSi8120/NSi8121/NSi8122

	I <sub>DD1</sub> (1M)		1.7	2.55	mA	All Input with 1Mbps, C <sub>L</sub> = 15pF	
	I <sub>DD2</sub> (1M)		1.27	1.91	mA		
	I <sub>DD1</sub> (10M)		1.73	2.6	mA	All Input with 10Mbps, C <sub>L</sub> = 15pF	
	I <sub>DD2</sub> (10M)		2.41	3.6	mA		
	I <sub>DD1</sub> (100M)		2.05	3.08	mA	All Input with 100Mbps, C <sub>L</sub> = 15pF	
	I <sub>DD2</sub> (100M)		14.05	21.08	mA		
	<b>NSi8121/ NSi8122</b>						
	I <sub>DD1</sub> (Q0)		0.98	1.47	mA	All Input 0V for NSi812xx0 Or All Input at supply for NSi812xx1	
	I <sub>DD2</sub> (Q0)		0.95	1.43	mA		
	I <sub>DD1</sub> (Q1)		2.14	3.21	mA	All Input at supply for NSi812xx0 Or All Input 0V for NSi812xx1	
	I <sub>DD2</sub> (Q1)		2.08	3.12	mA		
	I <sub>DD1</sub> (1M)		1.63	2.45	mA	All Input with 1Mbps, C <sub>L</sub> = 15pF	
I <sub>DD2</sub> (1M)		1.59	2.39	mA			
I <sub>DD1</sub> (10M)		2.22	3.33	mA	All Input with 10Mbps, C <sub>L</sub> = 15pF		
I <sub>DD2</sub> (10M)		2.25	3.38	mA			
I <sub>DD1</sub> (100M)		7.57	11.36	mA	All Input with 100Mbps, C <sub>L</sub> = 15pF		
I <sub>DD2</sub> (100M)		8.5	12.75	mA			
Data Rate	DR	0		150	Mbps		
Minimum Pulse Width	PW			5.0	ns		
Propagation Delay	t <sub>PLH</sub>	5	9.20	15	ns	See <a href="#">Figure 2.7</a> , C <sub>L</sub> = 15pF	
	t <sub>PHL</sub>	5	10.40	15	ns	See <a href="#">Figure 2.7</a> , C <sub>L</sub> = 15pF	
Pulse Width Distortion  t <sub>PHL</sub> - t <sub>PLH</sub>	PWD			5.0	ns	See <a href="#">Figure 2.7</a> , C <sub>L</sub> = 15pF	
Rising Time	t <sub>r</sub>			5.0	ns	See <a href="#">Figure 2.7</a> , C <sub>L</sub> = 15pF	
Falling Time	t <sub>f</sub>			5.0	ns	See <a href="#">Figure 2.7</a> , C <sub>L</sub> = 15pF	
Peak Eye Diagram Jitter	t <sub>JIT</sub> (PK)		350		ps		
Channel-to-Channel Delay Skew	t <sub>SK</sub> (c2c)			2.5	ns		
Part-to-Part Delay Skew	t <sub>SK</sub> (p2p)			5.0	ns		

(VDD1=2.5V± 10%, VDD2=2.5V± 10%, Ta=-40°C to 125°C. Unless otherwise noted, Typical values are at VDD1 = 2.5V, VDD2 = 2.5V, Ta = 25°C)

Parameters	Symbol	Min	Typ	Max	Unit	Comments
------------	--------	-----	-----	-----	------	----------

# NSi8120/NSi8121/NSi8122

Supply current	<b>NSi8120</b>					
	$I_{DD1}(Q0)$		0.53	0.8	mA	All Input 0V for NSi8120x0 Or All Input at supply for NSi8120x1
	$I_{DD2}(Q0)$		1.1	1.65	mA	
	$I_{DD1}(Q1)$		2.85	4.28	mA	All Input at supply for NSi8120x0 Or All Input 0V for NSi8120x1
	$I_{DD2}(Q1)$		1.15	1.73	mA	
	$I_{DD1}(1M)$		1.63	2.45	mA	All Input with 1Mbps, $C_L = 15pF$
	$I_{DD2}(1M)$		1.21	1.82	mA	
	$I_{DD1}(10M)$		1.68	2.52	mA	All Input with 10Mbps, $C_L = 15pF$
	$I_{DD2}(10M)$		2.05	3.08	mA	
	$I_{DD1}(100M)$		1.95	2.93	mA	All Input with 100Mbps, $C_L = 15pF$
	$I_{DD2}(100M)$		10.4	15.6	mA	
	<b>NSi8121/ NSi8122</b>					
	$I_{DD1}(Q0)$		0.96	1.44	mA	All Input 0V for NSi812xx0 Or All Input at supply for NSi812xx1
	$I_{DD2}(Q0)$		0.93	1.395	mA	
	$I_{DD1}(Q1)$		2.11	3.165	mA	All Input at supply for NSi812xx0 Or All Input 0V for NSi812xx1
	$I_{DD2}(Q1)$		2.05	3.075	mA	
	$I_{DD1}(1M)$		1.58	2.37	mA	All Input with 1Mbps, $C_L = 15pF$
	$I_{DD2}(1M)$		1.54	2.31	mA	
	$I_{DD1}(10M)$		2.02	3.03	mA	All Input with 10Mbps, $C_L = 15pF$
	$I_{DD2}(10M)$		2.04	3.06	mA	
$I_{DD1}(100M)$		6.03	9.045	mA	All Input with 100Mbps, $C_L = 15pF$	
$I_{DD2}(100M)$		6	9	mA		
Data Rate	DR	0		150	Mbps	
Minimum Pulse Width	PW			5.0	ns	
Propagation Delay	$t_{PLH}$	5	10	15	ns	See <a href="#">Figure 2.7</a> , $C_L = 15pF$
	$t_{PHL}$	5	10	15	ns	See <a href="#">Figure 2.7</a> , $C_L = 15pF$
Pulse Width Distortion $ t_{PHL} - t_{PLH} $	PWD			5.0	ns	See <a href="#">Figure 2.7</a> , $C_L = 15pF$
Rising Time	$t_r$			5.0	ns	See <a href="#">Figure 2.7</a> , $C_L = 15pF$
Falling Time	$t_f$			5.0	ns	See <a href="#">Figure 2.7</a> , $C_L = 15pF$
Peak Eye Diagram Jitter	$t_{JIT}(PK)$		350		ps	
Channel-to-Channel Delay Skew	$t_{SK}(c2c)$			2.5	ns	

# NSi8120/NSi8121/NSi8122

Part-to-Part Delay Skew	$t_{sk}(p2p)$			5.0	ns	
-------------------------	---------------	--	--	-----	----	--

## 2.4. TYPICAL PERFORMANCE CHARACTERISTICS

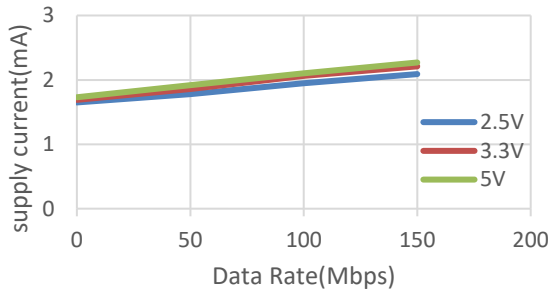

Figure 2.1 NSi8120 VDD1 Supply Current vs Data Rate

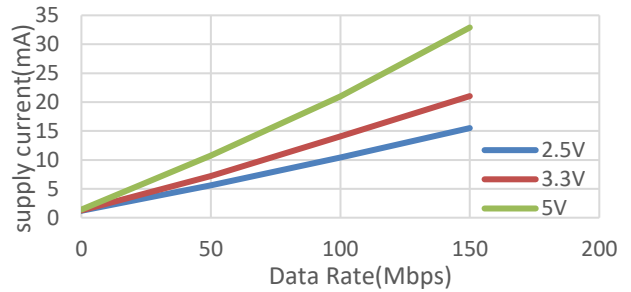

Figure 2.2 NSi8120 VDD2 Supply Current vs Data Rate

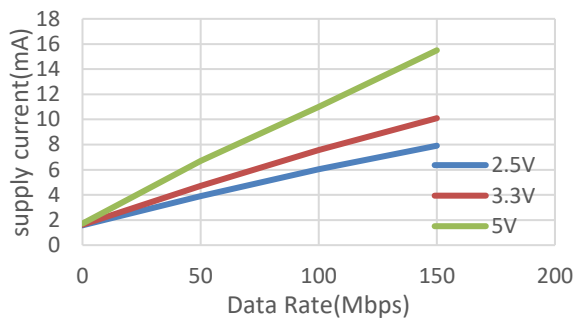

Figure 2.3 NSi8121/ NSi8122 VDD1 Supply Current vs Data Rate

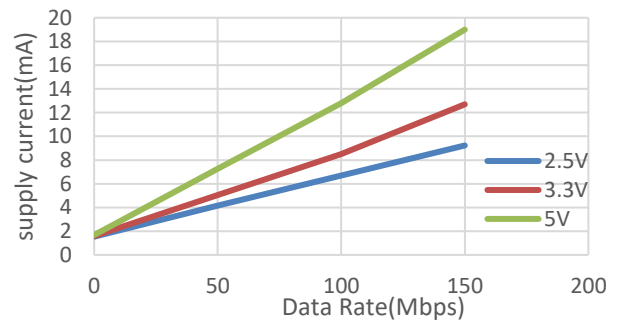

Figure 2.4 NSi8121/ NSi8122 VDD2 Supply Current vs Data Rate

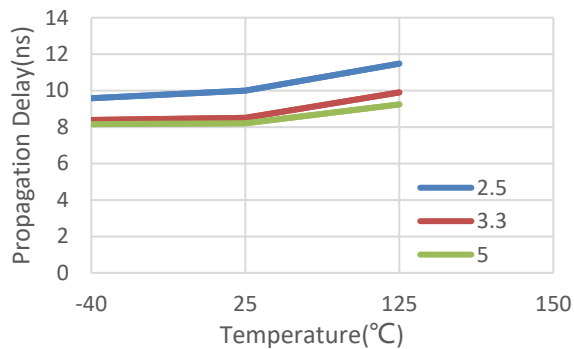

Figure 2.5 Rising Edge Propagation Delay Vs Temp

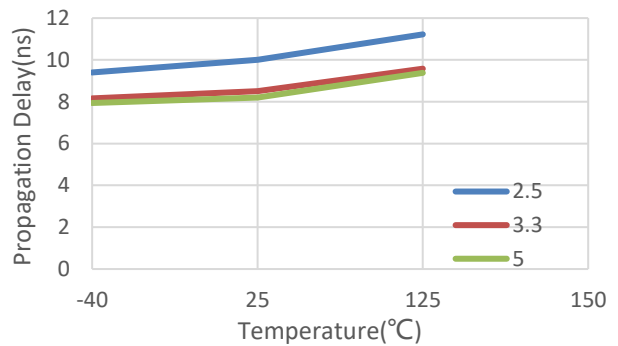

Figure 2.6 Falling Edge Propagation Delay Vs Temp

## 2.5. PARAMETER MEASUREMENT INFORMATION

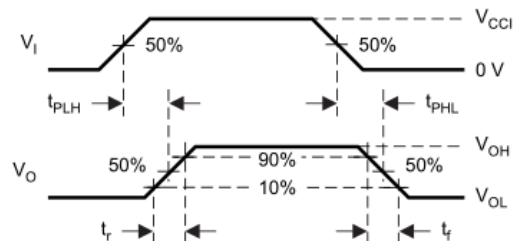
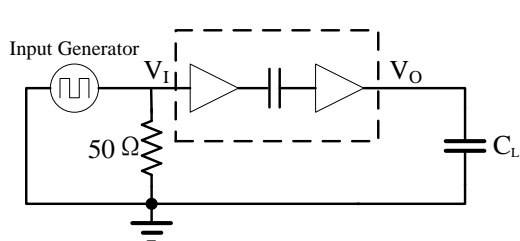

Figure 2.7 Switching Characteristics Test Circuit and Waveform

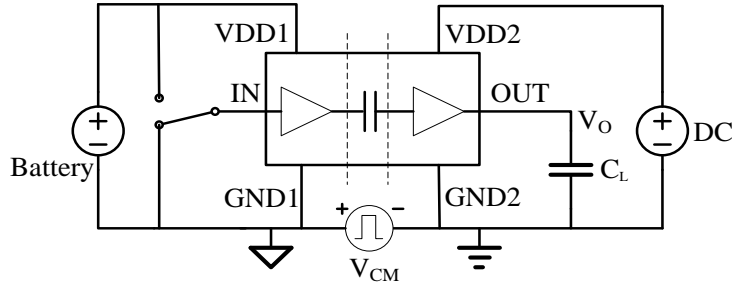

Figure 2.8 Common-Mode Transient Immunity Test Circuit

## 3.0 HIGH VOLTAGE FEATURE DESCRIPTION

### 3.1. INSULATION AND SAFETY RELATED SPECIFICATIONS

Parameters	Symbol	Value		Unit	Comments
		SOIC-8	SOIC-16		
Minimum External Air Gap (Clearance)	L(I01)	4.0	8.0	mm	Shortest terminal-to-terminal distance through air
Minimum External Tracking (Creepage)	L(I02)	4.0	8.0	mm	Shortest terminal-to-terminal distance across the package surface
Minimum internal gap	DTI	20		um	Distance through insulation
Tracking Resistance(Comparative Tracking Index)	CTI	>400		V	DIN EN 60112 (VDE 0303-11); IEC 60112
Material Group		II			

### 3.2. DIN VDE V 0884-11 (VDE V 0884-11) :2017-01 INSULATION CHARATERISTICS

Description	Test Condition	Symbol	Value	Unit
			SOIC-8	SOIC-16
Installation Classification per DIN VDE 0110				
For Rated Mains Voltage $\leq 150V_{rms}$			I to IV	I to IV
For Rated Mains Voltage $\leq 300V_{rms}$			I to III	I to IV
For Rated Mains Voltage $\leq 400V_{rms}$			I to III	I to IV
Climatic Classification			10/105/21	10/105/21

Pollution Degree per DIN VDE 0110, Table 1			2	2	
Maximum repetitive isolation voltage		VIORM	565	849	Vpeak
Input to Output Test Voltage, Method B1	$V_{IORM} \times 1.5 = V_{pd(m)}$ , 100% production test, $t_{ini} = t_m = 1$ sec, partial discharge < 5 pC	$V_{pd(m)}$	847	1273	Vpeak
Input to Output Test Voltage, Method A					
After Environmental Tests Subgroup 1	$V_{IORM} \times 1.2 = V_{pd(m)}$ , $t_{ini} = 60$ sec, $t_m = 10$ sec, partial discharge < 5 pC	$V_{pd(m)}$	678	1018	Vpeak
After Input and /or Safety Test Subgroup 2 and Subgroup 3	$V_{IORM} \times 1.2 = V_{pd(m)}$ , $t_{ini} = 60$ sec, $t_m = 10$ sec, partial discharge < 5 pC	$V_{pd(m)}$	678	1018	Vpeak
Maximum transient isolation voltage	$t = 60$ sec	VIOTM	5300	7000	Vpeak
Maximum Surge Isolation Voltage	Test method per IEC60065, 1.2/50us waveform, $V_{TEST} = V_{IOSM} \times 1.3$	VIOSM	5384	5384	Vpeak
Isolation resistance	$V_{IO} = 500V$	RIO	$>10^9$	$>10^9$	$\Omega$
Isolation capacitance	$f = 1MHz$	CIO	0.6	0.6	pF
Input capacitance		CI	2	2	pF
Total Power Dissipation at 25°C		Ps		1499	mW
Safety input, output, or supply current	$\theta_{JA} = 140$ °C/W, $V_I = 5.5$ V, $T_J = 150$ °C, $T_A = 25$ °C	Is	160		mA
	$\theta_{JA} = 84$ °C/W, $V_I = 5.5$ V, $T_J = 150$ °C, $T_A = 25$ °C			237	mA
Case Temperature		Ts	150	150	°C

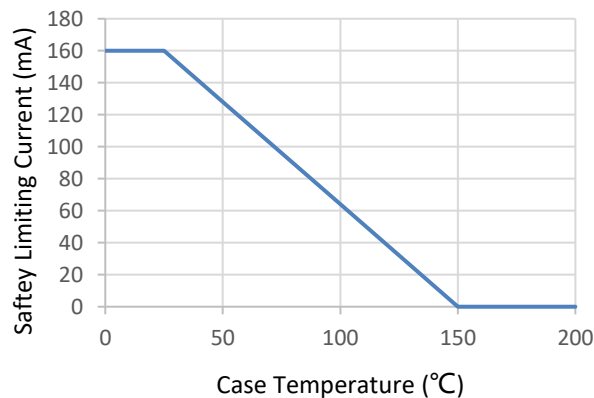

# NSi8120/NSi8121/NSi8122

Figure 3.1 NSi8120N/NSi8121N/NSi8122N Thermal Derating Curve, Dependence of Safety Limiting Values with Case Temperature per DIN VDE V 0884-11

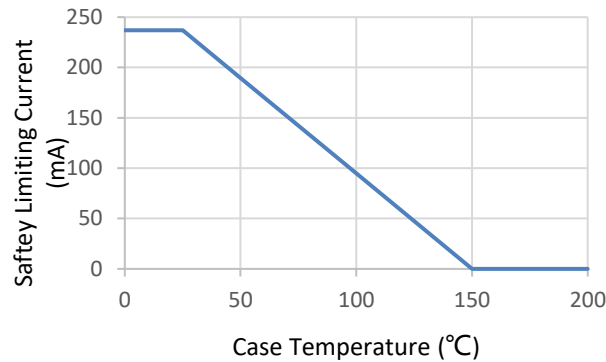

Figure 3.2 NSi8120W/NSi8121W/NSi8122W Thermal Derating Curve, Dependence of Safety Limiting Values with Case Temperature per DIN VDE V 0884-11

### 3.3. REGULATORY INFORMATION

The NSi8120N/NSi8121N/NSi8122N are approved by the organizations listed in table.

	<i>CUL</i>	<i>VDE</i>	<i>CQC</i>
UL 1577 Component Recognition Program <sup>1</sup>	Approved under CSA Component Acceptance Notice 5A	DIN VDE V 0884-11:2017-01 <sup>2</sup>	Certified by CQC11-471543-2012 GB4943.1-2011
Single Protection, 3750V <sub>rms</sub> Isolation voltage	Single Protection, 3750V <sub>rms</sub> Isolation voltage	Basic Insulation 565V <sub>peak</sub> , V <sub>IOSM</sub> =5384V <sub>peak</sub>	Basic insulation at 400V <sub>rms</sub> (565V <sub>peak</sub> )
File (E500602)	File (E500602)	File (5024579-4880-0001)	File (pending)

<sup>1</sup> In accordance with UL 1577, each NSi8120N/NSi8121N/NSi8122N is proof tested by applying an insulation test voltage  $\geq 4500$  V<sub>rms</sub> for 1 sec.

<sup>2</sup> In accordance with DIN VDE V 0884-11, each NSi8120N/NSi8121N/NSi8122N is proof tested by applying an insulation test voltage  $\geq 847$  V<sub>peak</sub> for 1 sec (partial discharge detection limit = 5 pC). The \* marking branded on the component designates DIN VDE V 0884-11 approval.

The NSi8120W/NSi8121W/NSi8122W are approved by the organizations listed in table.

	<i>CUL</i>	<i>VDE</i>	<i>CQC</i>
UL 1577 Component Recognition Program <sup>1</sup>	Approved under CSA Component Acceptance Notice 5A	DIN VDE V 0884-11(VDE V 0884-11):2017-01 <sup>2</sup>	Certified by CQC11-471543-2012 GB4943.1-2011
Single Protection, 5000V <sub>rms</sub> Isolation voltage	Single Protection, 5000V <sub>rms</sub> Isolation voltage	Basic Insulation 849V <sub>peak</sub> , V <sub>IOSM</sub> =5384V <sub>peak</sub>	Basic insulation at 800V <sub>rms</sub> (1131V <sub>peak</sub> ) Reinforced insulation at 400V <sub>rms</sub> (565V <sub>peak</sub> )
File (E500602)	File (E500602)	File (5024579-4880-0001)	File (pending)

<sup>1</sup> In accordance with UL 1577, each NSi8120W/NSi8121W/NSi8122W is proof tested by applying an insulation test voltage  $\geq 6000$  V<sub>rms</sub> for 1 sec.

<sup>2</sup> In accordance with DIN VDE V 0884-11, each NSi8120W/NSi8121W/NSi8122W is proof tested by applying an insulation test voltage  $\geq 1273$  V<sub>peak</sub> for 1 sec (partial discharge detection limit = 5 pC). The \* marking branded on the component designates DIN VDE V 0884-11 approval.

## 4.0 FUNCTION DESCRIPTION

The NSi812x is a Dual-channel digital isolator based on a capacitive isolation barrier technique. The digital signal is modulated with RF carrier generated by the internal oscillator at the Transmitter side. Then it is transferred through the capacitive isolation barrier and demodulated at the Receiver side.

The NSi812x devices are high reliability dual-channel digital isolator with AEC-Q100 qualified. The NSi812x device is safety certified by UL1577 support several insulation withstand voltages (3.75kV<sub>rms</sub>, 5kV<sub>rms</sub>), while providing high electromagnetic immunity and low emissions at low power consumption. The data rate of the NSi812x is up to 150Mbps, and the common-mode transient immunity (CMTI) is up to 150kV/us. The NSi812x device provides digital channel direction configuration and the default output level configuration when the input power is lost. Wide supply voltage of the NSi812x device support to connect with most digital interface directly, easy to do the level shift. High system level EMC performance enhance reliability and stability of use.

The NSi812x has a default output status when VDDIN is unready and VDDOUT is ready as shown in Table 4.1, which helps for diagnosis when power is missing at the transmitter side. The output B follows the same status with the input A within 60us after powering up.

Table 4.1 Output status vs. power status

Input	VDD1 status	VDD2 status	Output	Comment
H <sup>1</sup>	Ready	Ready	H	Normal operation.
L <sup>2</sup>	Ready	Ready	L	
X <sup>3</sup>	Unready	Ready	L H	The output follows the same status with the input within 60us after input side VDD1 is powered on.
X	Ready	Unready	X	The output follows the same status with the input within 60us after output side VDD2 is powered on.

<sup>1</sup> H=Logic high

<sup>2</sup> L=Logic low

<sup>3</sup> X=Logic low or logic high

## 5.0 APPLICATION NOTE

### 5.1. PCB LAYOUT

The NSi812x requires a 0.1 μF bypass capacitor between VDD1 and GND1, VDD2 and GND2. The capacitor should be placed as close as possible to the package. Figure 5.1 to Figure 5.4 show the recommended PCB layout, make sure the space under the chip should keep free from planes, traces, pads and via. To enhance the robustness of a design, the user may also include resistors (50–300 Ω ) in series with the inputs and outputs if the system is excessively noisy. The series resistors also improve the system reliability such as latch-up immunity.

The typical output impedance of an isolator driver channel is approximately 50 Ω, ±40%. When driving loads where transmission line effects will be a factor, output pins should be appropriately terminated with controlled impedance PCB traces.

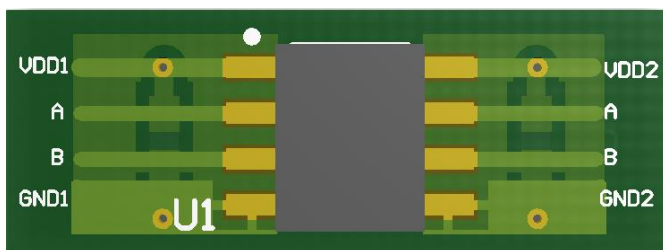

Figure 5.1 Recommended PCB Layout — Top Layer

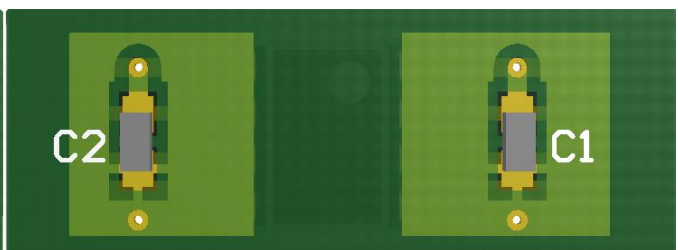

Figure 5.2 Recommended PCB Layout — Bottom Layer

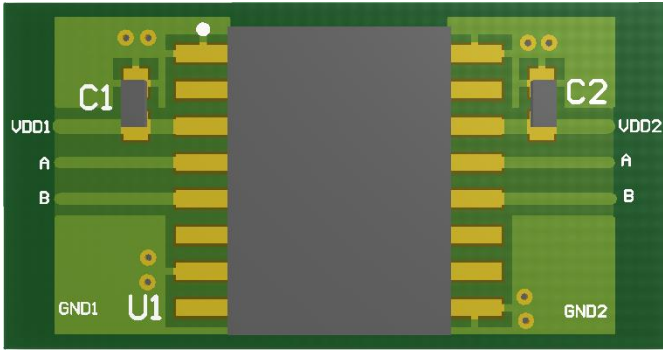

Figure 5.3 Recommended PCB Layout — Top Layer

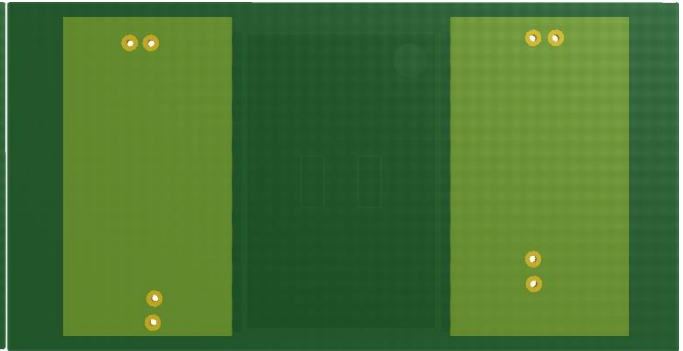

Figure 5.4 Recommended PCB Layout — Bottom Layer

## 5.2. HIGH SPEED PERFORMANCE

Figure 5.5 shows the eye diagram of NSi812x at 200Mbps data rate output. The result shows a typical measurement on the NSi812x with 350ps p-p jitter.

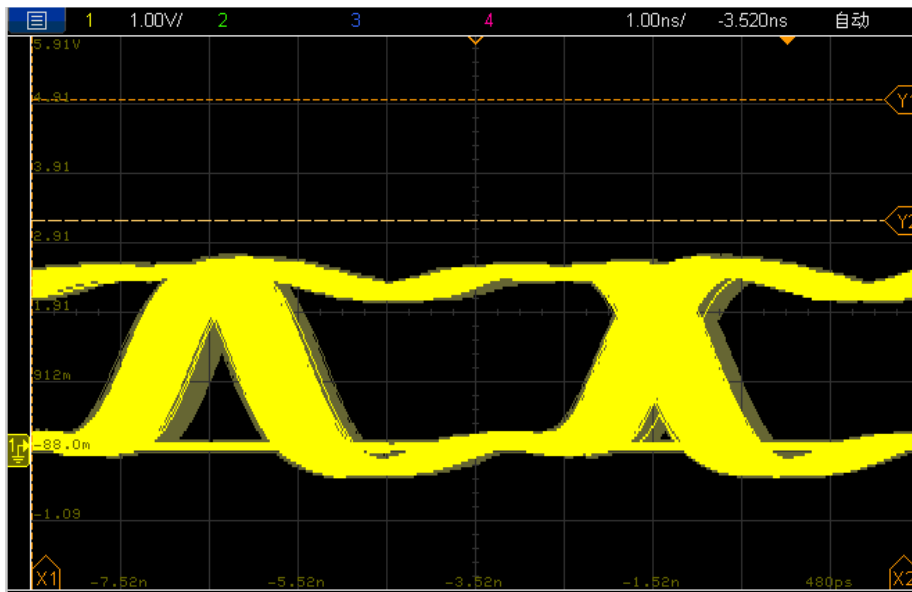

Figure 5.5 NSi812x Eye Diagram

## 5.3. TYPICAL SUPPLY CURRENT EQUATIONS

The typical supply current of NSi812x can be calculated using below equations.  $I_{DD1}$  and  $I_{DD2}$  are typical supply currents measured in mA,  $f$  is data rate measured in Mbps,  $C_L$  is the capacitive load measured in pF

**NSi8120:**

$$I_{DD1} = 0.19 * a1 + 1.45 * b1 + 0.82 * c1.$$

$$I_{DD2} = 1.36 + VDD1 * f * C_L * c1 * 10^{-9}$$

When  $a1$  is the channel number of low input at side 1,  $b1$  is the channel number of high input at side 1,  $c1$  is the channel number of switch signal input at side 1.

**NSi8121/ NSi8122:**

$$I_{DD1} = 0.87 + 1.26 * b1 + 0.63 * c1 + VDD1 * f * C_L * c2 * 10^{-9}$$

$$I_{DD2} = 0.87 + 1.26 * b2 + 0.63 * c2 + VDD1 * f * C_L * c1 * 10^{-9}$$

# NSi8120/NSi8121/NSi8122

When b1 is the channel number of high input at side 1, c1 is the channel number of switch signal input at side 1, b2 is the channel number of high input at side 2, c2 is the channel number of switch signal input at side 2.

## 6.0 PACKAGE INFORMATION

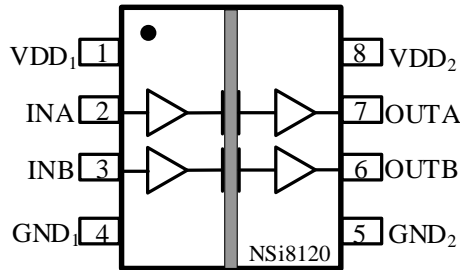

Figure 6.1 NSi8120N Package

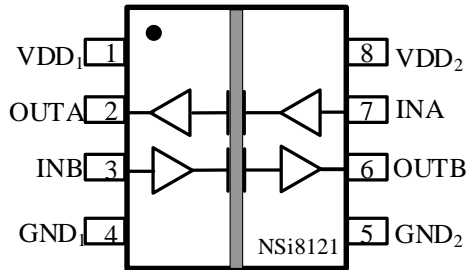

Figure 6.2 NSi8121N Package

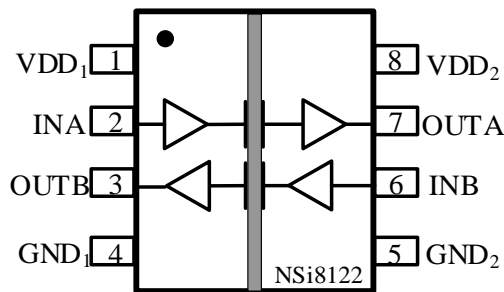

Figure 6.3 NSi8122N Package

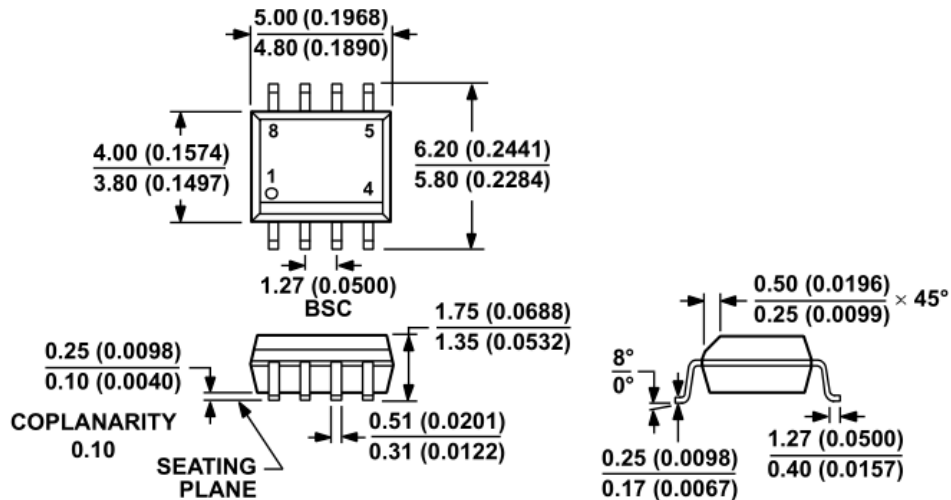

Figure 6.4 SOIC8 Package Shape and Dimension in millimeters (inches)

Table 6.1 NSi8120N/ NSi8121N/ NSi8122N Pin Configuration and Description

NSi8120N PIN NO.	NSi8121N PIN NO.	NSi8122N PIN NO.	SYMBOL	FUNCTION
1	1	1	VDD1	Power Supply for Isolator Side 1
2	7	2	INA	Logic Input A

# NSi8120/NSi8121/NSi8122

3	3	6	INB	Logic Input B
4	4	4	GND1	Ground 1, the ground reference for Isolator Side 1
5	5	5	GND2	Ground 2, the ground reference for Isolator Side 2
6	6	3	OUTB	Logic Output B
7	2	7	OUTA	Logic Output A
8	8	8	VDD2	Power Supply for Isolator Side 2

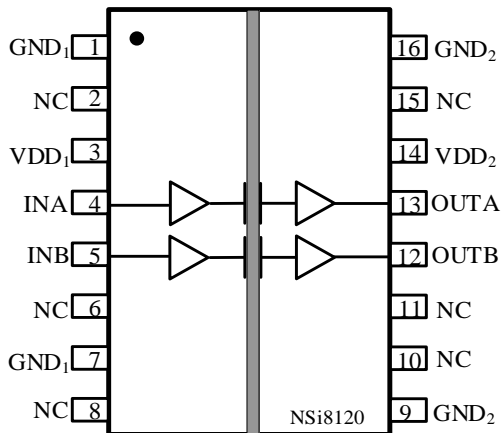

Figure 6.5 NSi8120W Package

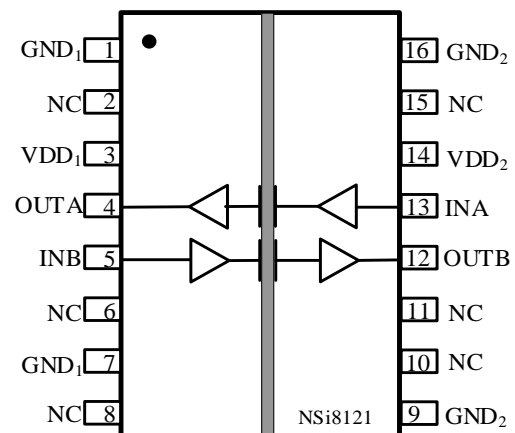

Figure 6.6 NSi8121W Package

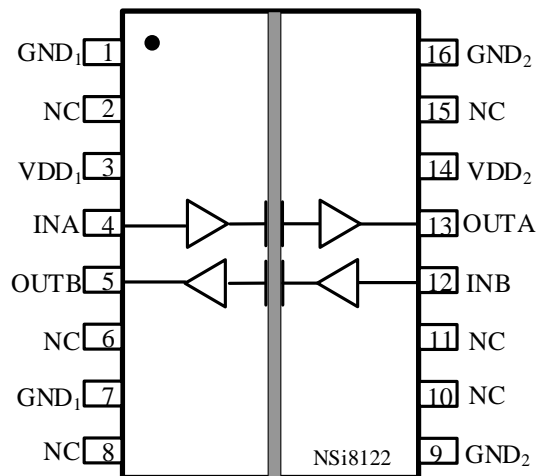

Figure 6.7 NSi8122W Package

# NSi8120/NSi8121/NSi8122

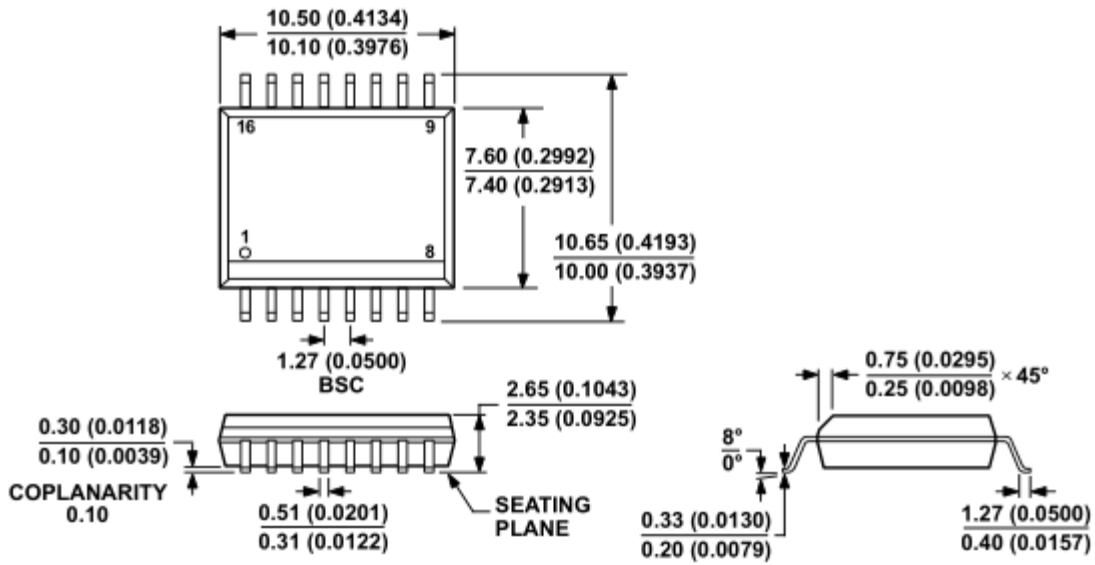
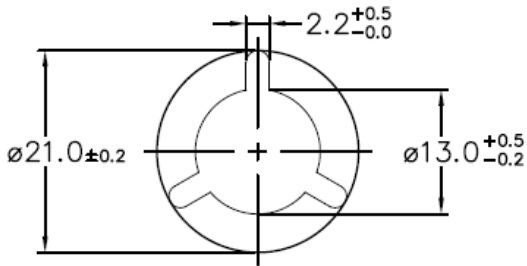
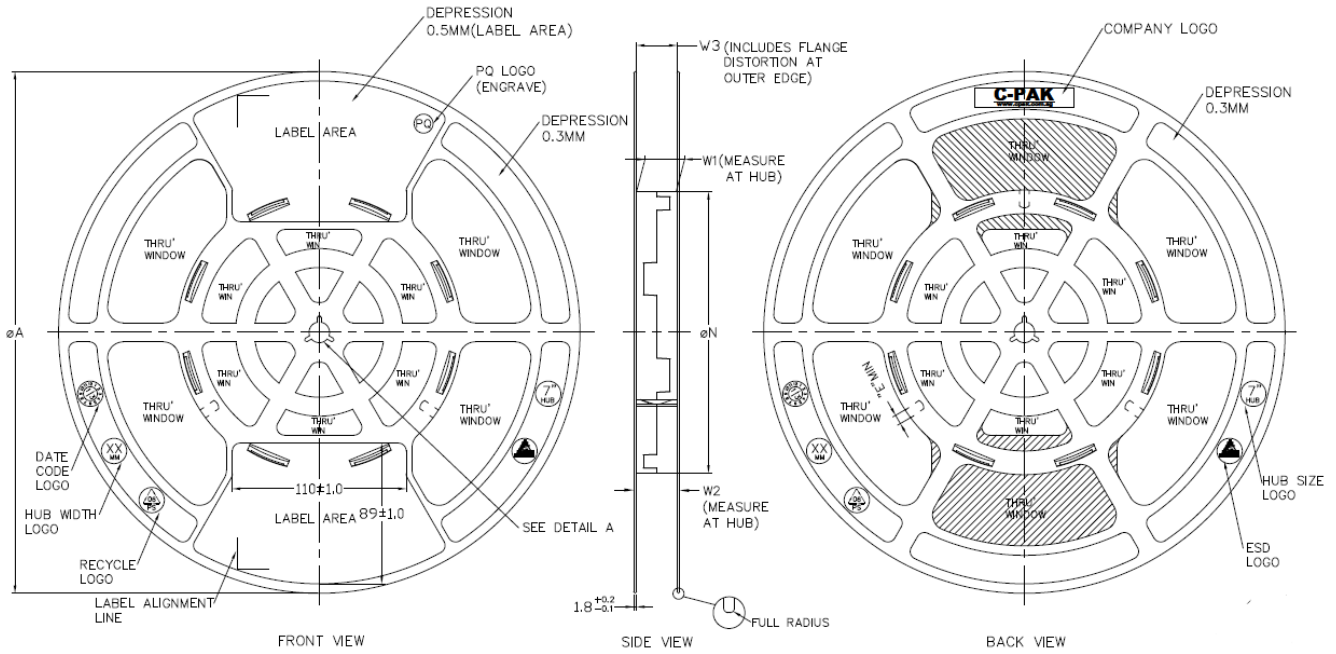

Figure 6.8 WB SOIC16 Package Shape and Dimension in millimeters and (inches)

Table 6.2 NSi8120W/ NSi8121W/ NSi8122W Pin Configuration and Description

NSi8120W PIN NO.	NSi8121W PIN NO.	NSi8122W PIN NO.	SYMBOL	FUNCTION
1	1	1	GND1	Ground 1, the ground reference for Isolator Side 1
2	2	2	NC	No Connection.
3	3	3	VDD1	Power Supply for Isolator Side 1
4	13	4	INA	Logic Input A
5	5	12	INB	Logic Input B
6	6	6	NC	No Connection.
7	7	7	GND1	Ground 1, the ground reference for Isolator Side 1
8	8	8	NC	No Connection.
9	9	9	GND2	Ground 2, the ground reference for Isolator Side 2
10	10	10	NC	No Connection.
11	11	11	NC	No Connection.
12	12	5	OUTB	Logic Output A
13	4	13	OUTA	Logic Output B
14	14	14	VDD2	Power Supply for Isolator Side 2
15	15	15	NC	No Connection.
16	16	16	GND2	Ground 2, the ground reference for Isolator Side 2

7.0 TAPE AND REEL INFORMATION



ARBOR HOLE  
DETAIL A  
SCALE : 3:1

PRODUCT SPECIFICATION						
TAPE WIDTH	$\phi A$ $\pm 2.0$	$\phi N$ $\pm 2.0$	W1	W2 (MAX)	W3	E (MIN)
08MM	330	178	$8.4^{+1.5}_{-0.0}$	14.4	SHALL ACCOMMODATE TAPE WIDTH WITHOUT INTERFERENCE	5.5
12MM	330	178	$12.4^{+2.0}_{-0.0}$	18.4		5.5
16MM	330	178	$16.4^{+2.0}_{-0.0}$	22.4		5.5
24MM	330	178	$24.4^{+2.0}_{-0.0}$	30.4		5.5
32MM	330	178	$32.4^{+2.0}_{-0.0}$	38.4		5.5

SURFACE RESISTIVITY			
LEGEND	SR RANGE	TYPE	COLOUR
A	BELOW $10^{12}$	ANTISTATIC	ALL TYPES
B	$10^8$ TO $10^{11}$	STATIC DISSIPATIVE	BLACK ONLY
C	$10^9$ & BELOW $10^9$	CONDUCTIVE (GENERIC)	BLACK ONLY
E	$10^8$ TO $10^{11}$	ANTISTATIC (COATED)	ALL TYPES



# NSi8120/NSi8121/NSi8122

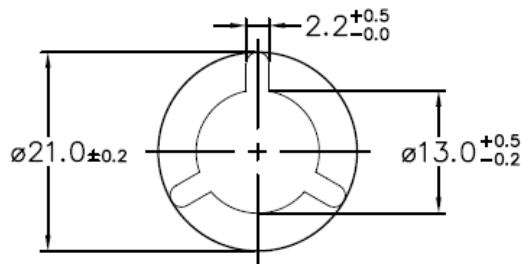

ARBOR HOLE  
DETAIL A  
SCALE : 3:1

PRODUCT SPECIFICATION						
TAPE WIDTH	ØA ±2.0	ØN ±2.0	W1	W2 (MAX)	W3	E (MIN)
08MM	330	178	8.4 <sup>+1.5</sup> / <sub>-0.0</sub>	14.4	SHALL ACCOMMODATE TAPE WIDTH WITHOUT INTERFERENCE	5.5
12MM	330	178	12.4 <sup>+2.0</sup> / <sub>-0.0</sub>	18.4		5.5
16MM	330	178	16.4 <sup>+2.0</sup> / <sub>-0.0</sub>	22.4		5.5
24MM	330	178	24.4 <sup>+2.0</sup> / <sub>-0.0</sub>	30.4		5.5
32MM	330	178	32.4 <sup>+2.0</sup> / <sub>-0.0</sub>	38.4		5.5

SURFACE RESISTIVITY			
LEGEND	SR RANGE	TYPE	COLOUR
A	BELOW 10 <sup>12</sup>	ANTISTATIC	ALL TYPES
B	10 <sup>8</sup> TO 10 <sup>11</sup>	STATIC DISSIPATIVE	BLACK ONLY
C	10 <sup>5</sup> & BELOW 10 <sup>5</sup>	CONDUCTIVE (GENERIC)	BLACK ONLY
E	10 <sup>9</sup> TO 10 <sup>11</sup>	ANTISTATIC (COATED)	ALL TYPES

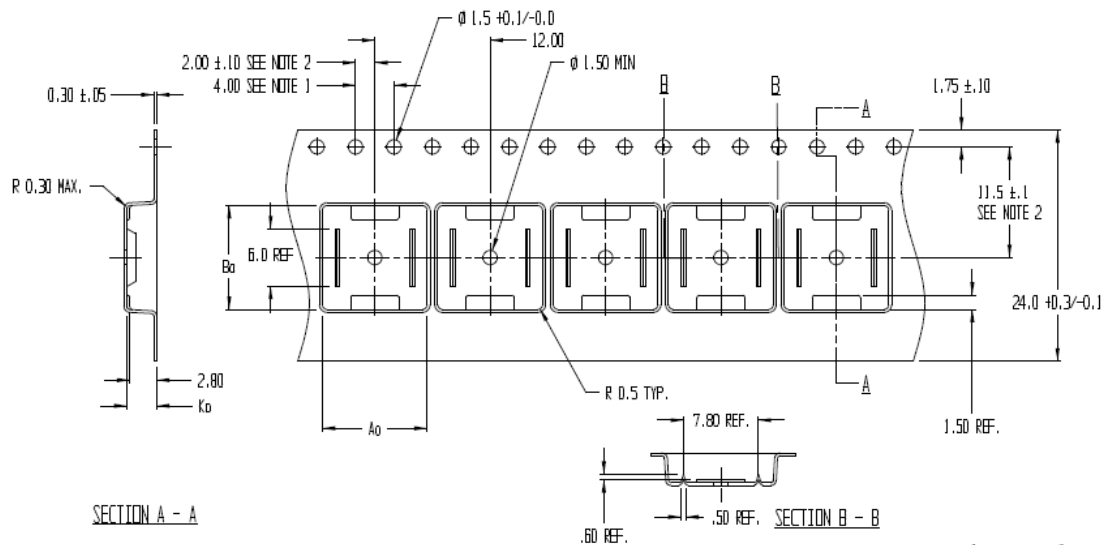

NOTES:

1. TO SPROCKET HOLE PITCH CUMULATIVE TOLERANCE ±0.2
2. POCKET POSITION RELATIVE TO SPROCKET HOLE MEASURED AS TRUE POSITION OF POCKET, NOT POCKET HOLE
3. A<sub>0</sub> AND B<sub>0</sub> ARE CALCULATED ON A PLANE AT A DISTANCE 'R' ABOVE THE BOTTOM OF THE POCKET.

A<sub>0</sub> = 10.90  
B<sub>0</sub> = 10.80  
K<sub>0</sub> = 3.1

Figure 7.2 Tape and Reel Information of WB SOIC16

## 8.0 ORDER INFORMATION

Part No.	Isolation Rating(kV)	Number of side 1 inputs	Number of side 2 inputs	Max Data Rate (Mbps)	Default Output State	Temperature	Automotive	Package
NSi8120N0	3.75	2	0	150	Low	-40 to 125°C	NO	SOIC8
NSi8120N1	3.75	2	0	150	High	-40 to 125°C	NO	SOIC8
NSi8121N0	3.75	1	1	150	Low	-40 to 125°C	NO	SOIC8
NSi8121N1	3.75	1	1	150	High	-40 to 125°C	NO	SOIC8
NSi8122N0	3.75	1	1	150	Low	-40 to 125°C	NO	SOIC8
NSi8122N1	3.75	1	1	150	High	-40 to 125°C	NO	SOIC8
NSi8120W0	5	2	0	150	Low	-40 to 125°C	NO	WB SOIC16
NSi8120W1	5	2	0	150	High	-40 to 125°C	NO	WB SOIC16
NSi8121W0	5	1	1	150	Low	-40 to 125°C	NO	WB SOIC16
NSi8121W1	5	1	1	150	High	-40 to 125°C	NO	WB SOIC16
NSi8122W0	5	1	1	150	Low	-40 to 125°C	NO	WB SOIC16
NSi8122W1	5	1	1	150	High	-40 to 125°C	NO	WB SOIC16
NSi8120N0Q	3.75	2	0	150	Low	-40 to 125°C	YES	SOIC8
NSi8120N1Q	3.75	2	0	150	High	-40 to 125°C	YES	SOIC8
NSi8121N0Q	3.75	1	1	150	Low	-40 to 125°C	YES	SOIC8
NSi8121N1Q	3.75	1	1	150	High	-40 to 125°C	YES	SOIC8
NSi8122N0Q	3.75	1	1	150	Low	-40 to 125°C	YES	SOIC8
NSi8122N1Q	3.75	1	1	150	High	-40 to 125°C	YES	SOIC8
NSi8120W0Q	5	2	0	150	Low	-40 to 125°C	YES	WB SOIC16
NSi8120W1Q	5	2	0	150	High	-40 to 125°C	YES	WB SOIC16
NSi8121W0Q	5	1	1	150	Low	-40 to 125°C	YES	WB SOIC16
NSi8121W1Q	5	1	1	150	High	-40 to 125°C	YES	WB SOIC16
NSi8122W0Q	5	1	1	150	Low	-40 to 125°C	YES	WB SOIC16
NSi8122W1Q	5	1	1	150	High	-40 to 125°C	YES	WB SOIC16

NOTE: All packages are RoHS-compliant with peak reflow temperatures of 260 °C according to the JEDEC industry standard classifications and peak solder temperatures.  
All devices are AEC-Q100 qualified.

### Part Number Rule:

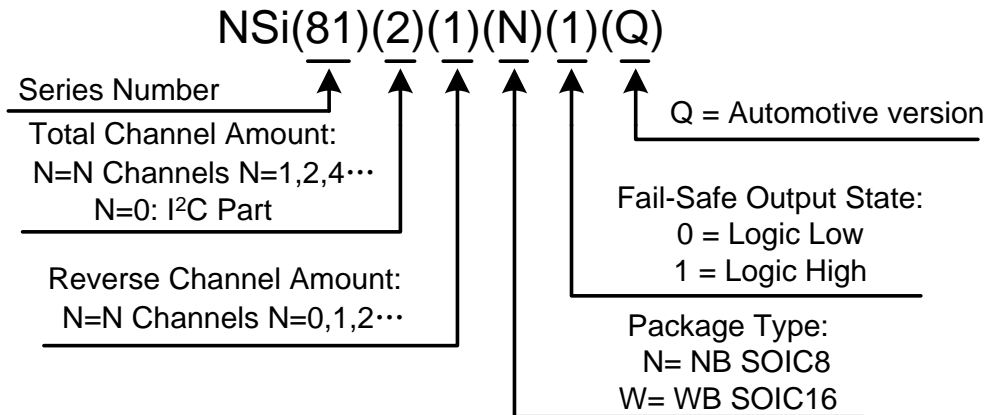

## 9.0 REVISION HISTORY

---

Revision	Description	Date
1.0	Original	2017/11/15
1.1	Change to Ordering information	2018/3/26
1.2	Add maximum operation current specification.	2018/6/20
1.3	Change block diagram	2018/7/28
1.4	Correct Table 6.2 Pin No.	2018/8/20
1.5	Add specification "Input Pull high or low Current"	2018/9/10
1.6	Add "Maximum Input/Output Pulse Voltage"	2018/10/9
1.7	Change to Ordering information	2018/12/20
1.8	Change Certification Information	2019/06/17
1.9	Add Recommended operating conditions	2020/2/27